

ELCSYS Control Unit Fitting and Installation Guidelines

Contents

1. Introduction
2. Installing the Control Unit
 - a. Prepare the Control Unit for wall mounting.
 - b. Find a suitable location for the Control Unit
 - c. Plan the power cabling
 - d. Plan the switch plate wiring
 - e. Install the Modules and Commissioning
3. Operating the Control Modules from the switch plates
 - a. Standard Dimmer Control
 - b. Preset Dimmer Control
 - c. Appliance Control and Blind Control
 - d. 'All Off' Control
4. Trouble shooting quick guide
 - a. Switch does not operate
 - b. On / Off does not operate
 - c. The Dimmer switch does not operate
5. Control Unit / Switch Plate wiring guide example
6. Cable Management Planning
7. Technical Specification

1. Introduction

The ELCSYS Control Unit can be used to control up to six separate lighting functions or powering six separate appliances or a combination of these by using the appropriate ELCSYS control modules. Each dimming module can be used for all incandescent lighting including low voltage lights (when using the appropriate power supplies). Each individual module supply is capable in supplying up to 720 Watts which equates to 14 Halogen bulbs rated at 50 Watts. The unit cannot be used with any other module or switch plate other than that specified by ELCSYS. The modules consist of a separate control and power module and the models currently available are:

Model Type	Power Model Number	Control Model Number
ELCSYS Standard Dimmer Module	PDM-002	CSM-002
ELCSYS Preset Dimmer Module	PDM-002	CPM-003
ELCSYS Preset Electro-Mechanical Dimmer Module	PEM-002	CEM-003

ELCSYS Preset Electro-Mechanical Timer / Dimmer Module	PEM-002	CTEM-002
ELCSYS Appliance Module	PAM-001	CAM-001
ELCSYS Electric Blind Module	PAM-002	CAM-001

2. Installing the Control Unit

Before installing please take care to read all the following instructions.

Before fitting and installing any electrical connections please consult a qualified electrician.

This Unit must be fitted by a qualified Electrician

a. Prepare the Control Unit for wall mounting.

The Control Unit dimensions are 208mm (H) by 370mm (W) by 108mm (D).

- i. Remove the faceplate by unscrewing the four screws.
- ii. Familiarise yourself with the modules to be fitted to the Control Unit. The Control unit has a high voltage section (single phase 240VAC in the upper half of the unit and a low voltage section at the bottom of the Unit. The Dimmer and Appliance modules are paired with the power module (PM1-6) installed in the top section with the control module (CM1-6) installed in the lower section. Note that a maximum of five Preset Dimming control modules can be installed per Control Unit. If you do require six to be installed then the Control Unit will require special modification contact ELCSYS for upgrading details. Note that if 6 Dimming units are required then a Standard Dimming module can be fitted in location CM6 without any modification to the Control Unit.
- iii. Familiarise yourself with the supply and load connection terminals in the top half of the unit as well as the switch plate connections to the IDC terminals in the lower half of the unit.
- iv. The Supply and Load are numbered 1 to 6 with the Supply always being connected to the lower tier of the double stacked clamp connector terminals. To insert a wire into the terminal prise open the clamp by inserting a small flat blade screw driver above the clamping hole and lever outwards.
- v. Locate the Control Unit's cable knockouts. There are 2 x 25mm and 9 x 20mm on the top and bottom of the unit and 1 x 32mm on each side. Only knockout the minimum amount of 20mm holes required starting at the top left in line with the first supply connector (see diagram 1.). This is because this supply connection is also used to provide power to the Control Unit itself. Do not knock out the top left 25mm hole.
- vi. Insert a 20mm rubber grommet into the hole unless you plan to use cable conduit to the control unit. It is recommended to use covered cable trunking dimensions, 50mm(H) x 50mm(W) installed horizontally above the control unit ensuring that the holes drilled into the side wall of the trunking does not exceed 18mm.

b. Find a suitable location for the Control Unit

- i. The Control Unit should be located on a dry and flat wall at a height of 1.7m above the floor.
- ii. The temperature for the location of the Control Unit should not fall below minus 5°C and rise above 45°C.
- iii. Note that power supply cables will need to be run from the Main power distribution board and to all the lighting and appliance loads. Also all the primary switch plates will need a direct connection to the Control Unit.
- iv. Place the Control Unit in the desired location to mark the fixing holes on the wall using the pre-drilled fixing holes. Depending on the thickness and consistency of the wall 4 x 40mm No.6 screws should be sufficient.

c. Plan the power cabling

- i. A minimum of a single mains supply, 240VAC is required to power the unit and supply the 1st Dimmer / Appliance Module. The supply should be connected to a suitably rated MCB fuse from the main power distribution supply. Consult a qualified electrician for specific requirements.
- ii. The Supply to the 1st Dimmer must be connected to the Live (L), Neutral (N) and Earth (E) connections as indicated within the Control Unit.
- iii. The recommended cable is Twin and Earth 1mm² BASEC approved 6242Y Cable, BS 6004, PVC insulated and sheathed in white PVC or similar.
- iv. The maximum load for each individual dimmer or appliance module should not exceed 3Amps. A separate supply feed should be supplied to each Dimmer / Appliance module within the Control Unit. However, if the total load for all of the dimmer / Appliance modules does not exceed 10Amps as well as having adequate supply fusing, then it is possible to loop the supply connections (L & N) together for each of the dimmer / appliance supply terminal connections.
- v. Again using the twin and earth 1mm² cable, the lights or appliances to be controlled, should be connected to the appropriate Module's Supply Connection. The Earth wire can be connected to either the module's terminal connection or to the Earth Bar.
- vi. The live load connection for all Dimmer (preset and standard) and the Appliance Modules should be connected to the Load terminal labelled L2. The Neutral load connection should be connected to the load terminal labelled N and Earth to the Earth Bar.
- vii. For bidirectional motor driven appliances such as electric blinds, the closing circuit should be connected to the L1 terminal located above the position of the Appliance Power Module. Note that the L1 terminal for all supplied connections is live when the Appliance is turned off.
- viii. For controlling an appliance such as a lamp stand or Television set, Connect the load terminals to a 5Amp type socket. This is to ensure that the load does not exceed the 3Amp rating of the Appliance power module by connecting a higher rated Appliance.
- ix. Ensure the supply is disconnected to the Control box when connecting the cables and fitting the power and control modules.

d. Plan the switch plate wiring

- i. The recommended cable for wiring to the switch plates is CW1308 internal multi-pair voice cable or internal / external grade LSOH CW103B multi-pair cable. These are available in 2,3,4,5,6,10 and 12 pairs and it is advisable to allow for spare capacity and expansion as your requirements change.
- ii. The standard switch plate is should be fixed to a standard single 1" depth metal box that is earthed with standard 5mm Earth cable.
- iii. There are 2 sets of IDC terminals for each Control Unit. A Maximum of 2 wires can be connected to individual terminals and therefore 4 separate switch plates can be connected directly to the Control unit (see note a). However switch plates can be linked together in series.
- iv. The total cable length from the Control Unit to the switch plate should not exceed 50 Metres.
- v. Plan which type of operation the module location should be. If module position 1 is for dimming then the connection terminal wiring for this module is located directly below the Dimming Control Module. Repeat this for all six modules as required.
- vi. Each dimming control requires 3 wires plus one for an earth connection. The terminal connections are Earth (E), Dimmer (D), Indicator (I) and ON / OFF (C).
- vii. Each appliance control requires 2 wires plus one for an earth connection. The terminal connections are Earth (E), Indicator (I) and ON / OFF (C).
- viii. The 'All Off' control requires 1 wire plus one for an earth connection. Note that for a multiple control switch plate only one earth connection is required for all switches on the plate.
- ix. To connect the wires to the IDC terminal use an IDC / Krone punch tool.
- x. Note down the colour codes for each switch connection and to aid the planning of the wiring configuration a cable management table is included in these guidelines.
- xi. Plan the 'All Off' operation and only loop the IDC terminals marked 'A' in the control unit for the lights or Appliances that require this operation. By looping all 6 modules will turn off all 6 lights / Appliances after pressing the 'All Off' button on the switch plate (see Note b).
- xii. The Jumper connection has multiple uses for example linking Control units together for the 'All Off' circuit operation if more than six individual units need to be switched off simultaneously .
- xiii. Notes on specific jumpering requirements:
 - (a) If more than 4 connections to the control box are required for one of the control modules in an isolated case, then the jumper connection can be used.
 - (b) If you require more than 6 'All Off' operations then loop a free 'A' from SW 1-6 Terminal to the Jumper terminal then link the Jumper terminal to another Control Unit's Jumper terminal and repeat the process in the 2nd Control Unit for up to 6 further 'All Off' operations, and so on.
 - (c) If you wish to utilise any spare wiring pairs from a multi-pair cable for use in another control unit, then these can be connected to the jumper connection and a separate 2 pair cable can be linked to the other control unit. If you require any other specific requirements then consult your ELCSYS representative.

e. Install the Modules and Commissioning

- i. The Control Unit modules are paired with a power module and cannot be interchanged. The power module located above the control module. The design is such that it is not possible to insert them the wrong way round.
- ii. Insert the Power and Control Modules into the Control Unit as planned.
- iii. If applicable; set the preset Dimming Control Module to 50% setting. This can be adjusted later to suit personal preferences.
- iv. For Preset Dimming Modules the blanking plates will need to be removed for each one. Remove the cover from the Face Plate by undoing the 8 Screws and then remove the Module Blanking Plate(s) and re-attach the cover plate.
- v. Replace the Face Plate and ensure that the Preset Dimming Control Modules are located properly into the face plate slot before tightening the 4 faceplate screws.
- vi. Power the unit by connecting to the main fused supply.
- vii. Leave all guidelines installation instructions, and planning reference material at the Control Unit.
- viii. Test all the switches for correct operations.

3. Operating the Control Modules from the switch plates

a. Standard Dimmer Control

To turn on or off: Press the button next to the LED indicator. Light illuminates to the last used memory setting.

To control the Dim: Press and hold the opposite button to increase output control. Release and press and hold to decrease the output control.

b. Preset Dimmer Control

To turn on or off: Press the button next to the LED indicator. Light illuminates to the preset adjustment set at the control unit.

To control the Dim press and hold the opposite button to increase output control. Release and press and hold to decrease the output control

c. Appliance Control and Blind Control

To turn on or off: Press the button next to the LED indicator.

d. 'All Off' Control

To turn off all lights and Appliances
Press the 'All Off' button once.

4. Trouble shooting quick guide

a. Switch does not operate

If none of the switches work on a single or multiple operation switch plate, check the Earth connection (E) at the switch plate and the Control Unit.

b. On / Off does not operate

If the On / off switch does not operate and the LED indicator does not illuminate check the Control connection (C) and the Earth connection (E) at the switch plate and the Control Unit.

c. The Dimmer switch does not operate

If the Dimmer Switch does not operate check the Dimmer connection (D) at the switch plate and the Control Unit.

Any other support issues please email Support at support@elcsys.com or telephone 0044 (0)1634 869208 and ask for ELCSYS support

For details of other ELCSYS switch plates, Control units and Light or Appliance modules check the website at <http://www.elcsys.com>
If you have any specific requirements contact us.

5. Control Unit / Switch Plate wiring guide example

This sample wiring aid has three switch plates which all have one dimmer control, one appliance control and the 'All Off' function. The Supply has been looped through to the second unit, two of the switch plates are connected directly to the Control Unit and the third switch plate is connected to the second switch plate. The 'All Off' (A) connection has been looped from position SW1 to SW2.

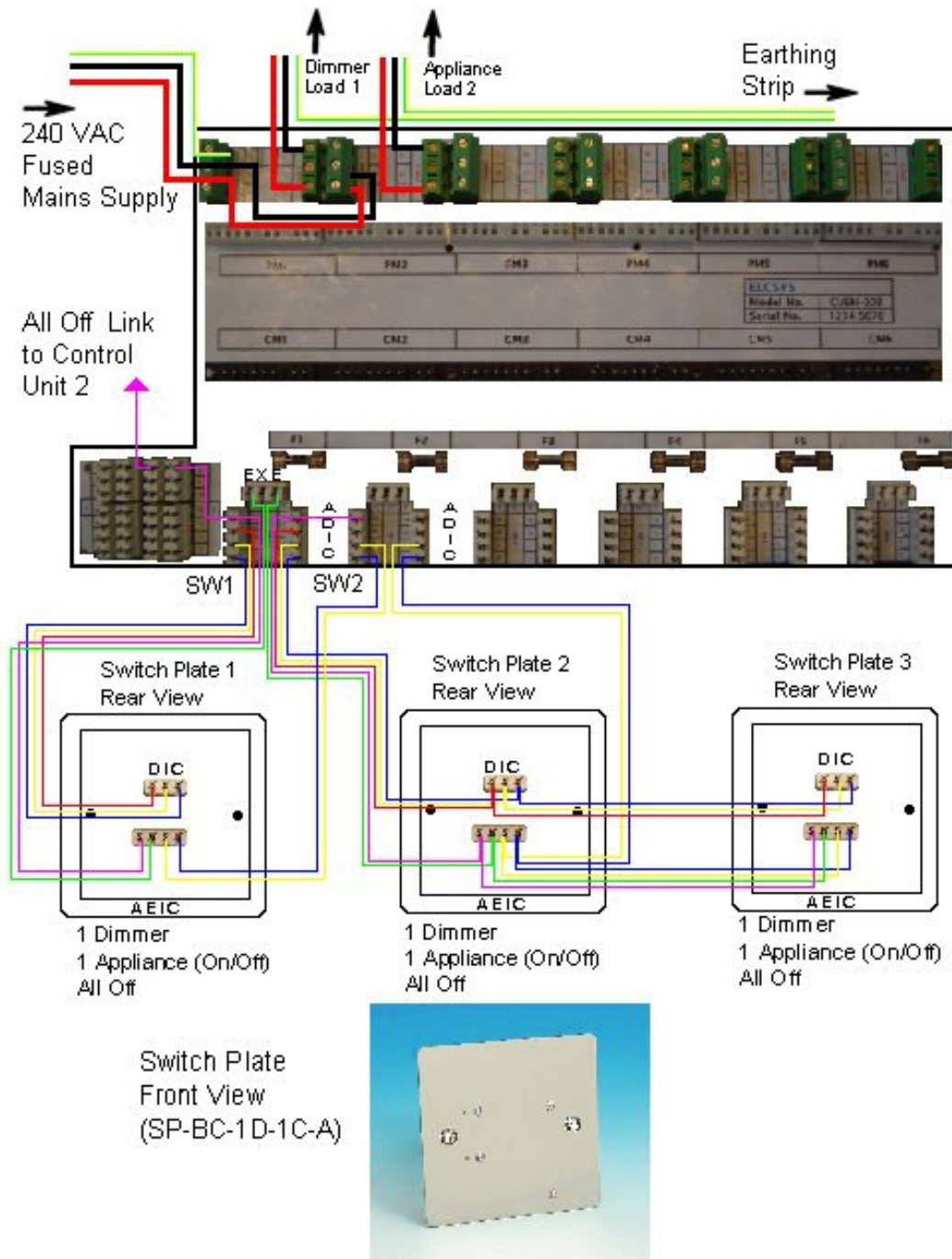

6. Cable Management Planning

Cable Management for Wiring Switch Plate to Control Unit

Location					Code	
					Origin SP	
					Destination CU	
Pair No	Wire	Colour Code	Switch	Module	Description	
1	A	White/Blue				
	B	Blue/White				
2	A	White/Orange				
	B	Orange/White				
3	A	White/Green				
	B	Green/White				
4	A	White/Brown				
	B	Brown/White				
5	A	White/Grey				
	B	Grey/White				
6	A	Red/Blue				
	B	Blue/Red				
7	A	Red/Orange				
	B	Orange/Red				
8	A	Red/Green				
	B	Green/Red				
9	A	Red/Brown				
	B	Brown/Red				
10	A	Red/Grey				
	B	Grey/Red				
11	A	Black/Blue				
	B	Blue/Black				
12	A	Black/Orange				
	B	Orange/Black				
13	A	Black/Green				
	B	Green/Black				
14	A	Black/Brown				
	B	Brown/Black				
15	A	Black/Grey				
	B	Grey/Black				
16	A	Yellow/Blue				
	B	Blue/Yellow				
17	A	Yellow/Orange				
	B	Orange/Yellow				
18	A	Yellow/Green				
	B	Green/Yellow				
19	A	Yellow/Brown				
	B	Brown/Yellow				
20	A	Yellow/Grey				
	B	Grey/Yellow				

7. Technical Specification

Control Unit Dimensions	208mm (H) by 370mm (W) by 108mm (D)
Enclosure Material	Metal
Level of protection	IP40
Operating Temperature	-5°C to +45°C
Test Certificates	EN60669-1:1999 & EN60669-2-1:1996/A11:2004
Rated Input Voltage	240V AC 50/60Hz single phase
Total Number of Supply Inputs	6
Total Number of switched Loads	6
Power Module capacity	6
Rated Output Voltage per module	240VAC 50/60Hz
Rated Current per Module	3A
Supply and Load Terminal type	Screw Clamp Terminal
Power cabling	Twin and Earth 1mm ² BASEC approved 6242Y Cable, BS 6004, PVC insulated and sheathed in white PVC or similar
Max number of 1mm ² wires per terminal	2
Total number of switch inputs	6
Max Number switch plates per switch input	4
Max Number of Preset Dimming Modules	5
Max Number of Standard Dimming Modules	6
Max Number of Appliance Modules	6
Max Number Preset Timed Delay Modules	1
Terminal type to switches	Krone IDC
Max number of wires per terminal	2
Output Voltage to switches	12V DC
Cable type to Switches	CW1308, CW1308B twisted pair
Max cable distance to switches	50M
Max Number Jumper Connections	14
Terminal Type for Jumper connections	IDC